

# YFB250 Timberwolf

---



The new YFB250 Timberwolf is a versatile ATV a wide range of people can enjoy. Like its namesake, it is smart, quick and tough. Designed for both work and play, it can haul loads on the farm all week long and spend the weekends trail riding in the mountains. It is powered by a reliable 4-stroke single-cylinder engine which delivers plenty of torque. Long-travel suspension gives it a smooth ride. And its affordable price will make it especially attractive.

# Timberwolf

---



---

## Technical Highlights

---

- 229cc, 4-stroke, SOHC, single-cylinder engine has lots of torque for low-speed efficiency.
- 5-speed transmission with reverse gear.
- Water-resistant Capacitor Discharge Ignition (CDI), automatic cam-chain tensioner and shaft drive.
- Push-button electric starter makes starting easy.
- Sturdy racks and trailer hitch for hauling loads.
- Long-travel front and rear suspension for a smooth ride over rough terrain.
- Powerful dual headlights cast a bright beam for working after dark.

---

## Engine

---

The Timberwolf is powered by a 229cc, wet-sump, SOHC 2-valve, air-cooled engine that boasts fat torque delivery and excellent reliability. It features large cylinder fins for more cooling capacity, making it ideal for slow-speed work. Power is transmitted to reliable shaft drive via a 5-speed transmission with reverse gear.

Electric starting makes the Timberwolf especially easy to operate. The CDI provides a hot spark for quick starting. This ignition is equipped with a battery backup system which ensures easy starting even at low cranking rpm. The ignition also features a roll-off prevention circuit to prevent the machine from moving when the engine is started in gear. If the machine is in gear, the engine can only be started with the brake on. An automatic cam-chain tensioner reduces maintenance chores.

# Timberwolf

---

## Body, Racks and Trailer Hitch

---

The Timberwolf features an all-new body and chassis. The modern styling and functional design give it added versatility making it easier to operate, yet strong enough for hard work.

Large racks give the Timberwolf plenty of carrying capacity. On the farm or in the mountains, stylish one-piece rack/fender units at both front and rear\* can carry a variety of loads with ease. And when something needs to be towed, there is a sturdy trailer hitch. It even comes with a handy luggage box beneath the rear rack for storing small items.



---

## Suspension, Tires and Brakes

---

New strut front and swingarm rear suspension have long wheel travel (125mm at both ends) for a smooth ride on rough ground. This makes the Timberwolf a comfortable ride. Large 22-inch front and rear tires and a soft seat enhance comfort further. In addition, a newly designed steering mechanism offers light yet precise steering control.

Mechanical drum brakes are used front and rear. Together with the soft, high-grip tires, they provide plenty of controllable stopping power. The rear brake is fully sealed to

prevent water, dirt or mud from interfering with brake performance.

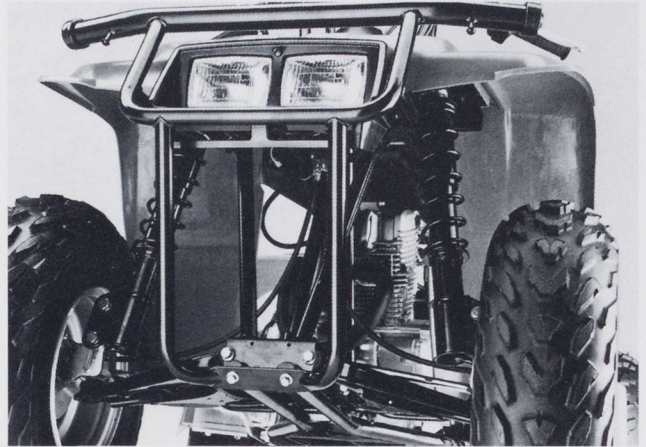

---

## Other Features

---

The Timberwolf comes equipped with powerful dual headlights. These cast a bright beam of light when working after dark. A neutral light and reverse light are also fitted for added convenience. \* \* \*

The new Timberwolf is a versatile ATV. It is sturdy enough for work, yet compact enough and easy enough to operate for leisure riding. Modern styling gives it extremely good looks.

And, best of all, an affordable price makes it even more attractive.

\*Canadian and other versions are equipped with steel-tube racks.



# Timberwolf

## ■ YFB250 Timberwolf SPECIFICATIONS ■

### ENGINE

Type.....	4-stroke, air-cooled, SOHC, single cylinder
Displacement.....	229.6cc
Bore and stroke.....	71.0 × 58.0mm
Compression ratio.....	8.7:1
Max. power (SAE).....	15.4BHP @7,000rpm
Max. torque (SAE).....	12.22 ft-lb. @6,000rpm
Carburetion.....	Mikuni VM24SH × 1
Ignition.....	Capacitor discharge
Starting.....	Electric
Lubrication.....	Wet sump
Transmission	
Type.....	5-forward, 1-reverse, constant mesh
Oil capacity.....	1.8 liters (1.9 qt; 1.6 Imp. qt.)
Primary reduction ratio.....	73/22 (3.318)
Secondary reduction ratio.....	19/18 × 46/11 (4.415)
1st gear ratio.....	34/12 (2.833)
2nd gear ratio.....	34/19 (1.789)
3rd gear ratio.....	29/22 (1.318)
4th gear ratio.....	26/25 (1.040)
5th gear ratio.....	23/28 (0.821)
Reverse gear ratio.....	41.500
Clutch type.....	Wet, automatic centrifugal

### CHASSIS

Overall length.....	1,740mm (68.6 in.)
Overall width.....	1,025mm (40.4 in.)
Overall height.....	1,082mm (42.6 in.)
Wheelbase.....	1,120mm (44.1 in.)
Min. ground clearance.....	155mm ( 6.1 in.)
Seat height.....	780mm (30.7 in.)
Front track.....	785mm (30.9 in.)
Rear track.....	770mm (30.3 in.)
Dry weight.....	178.0kg (396.9 lb.)
Fuel tank capacity.....	9.7 liters (2.14 gal.; 2.13 Imp. gal.)
Suspension	
Front.....	Strut (125mm wheel travel)
Rear.....	Swingarm (125mm wheel travel)
Brakes	
Front.....	Dual mechanical drums (110mm ø drum)
Rear.....	Single mechanical drum (160mm ø drum)
Tires	
Front.....	AT22 × 7-10
Rear.....	AT22 × 10-10

NOTE: The figures shown here are of U.S. model, and may vary in other countries.  
Specifications subject to change without notice.

# Timberwolf

---

■ YFB250 LEFT PROFILE

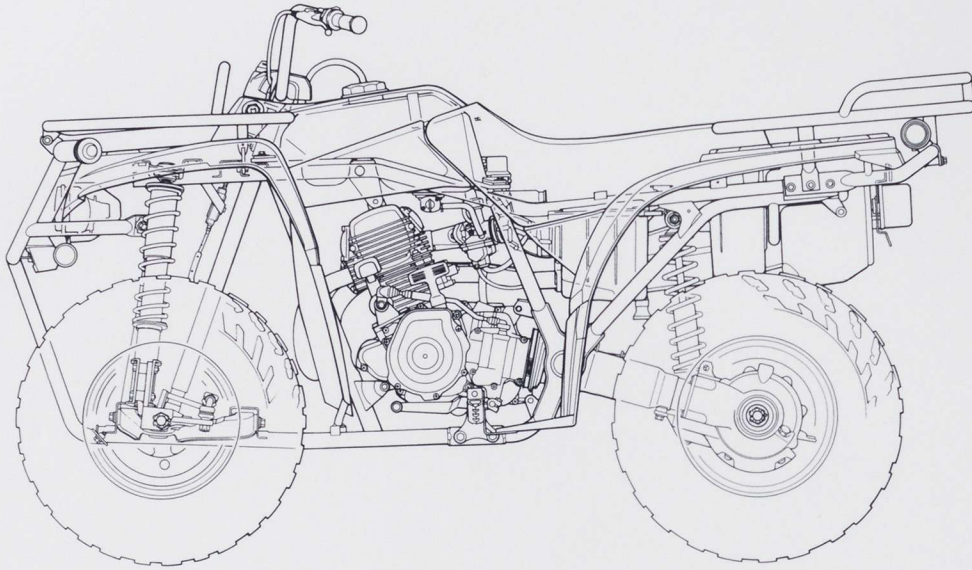

■ YFB250 (U.S. MODEL) LEFT PROFILE

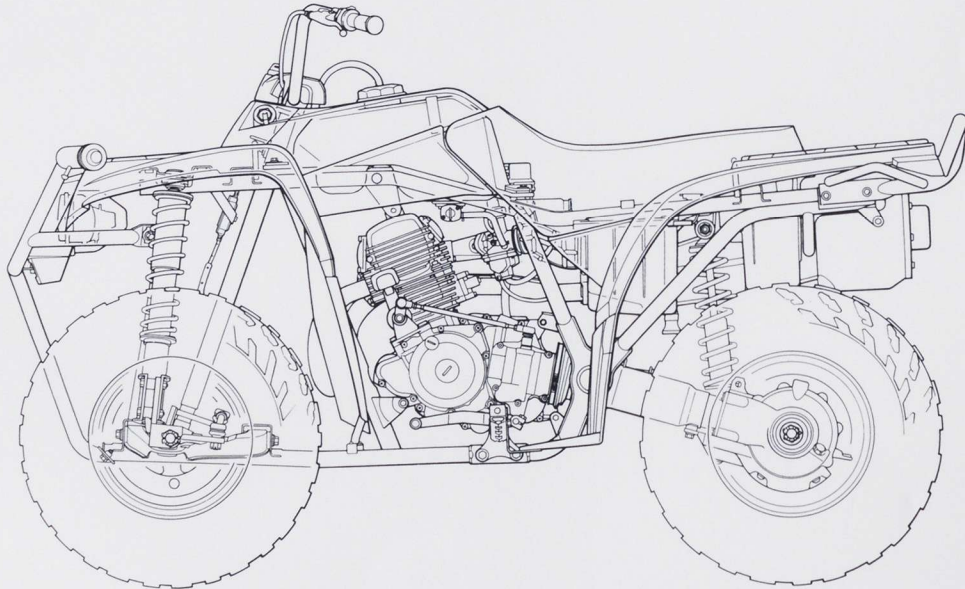

# Timberwolf

■ YFB250 ENGINE CUTAWAY

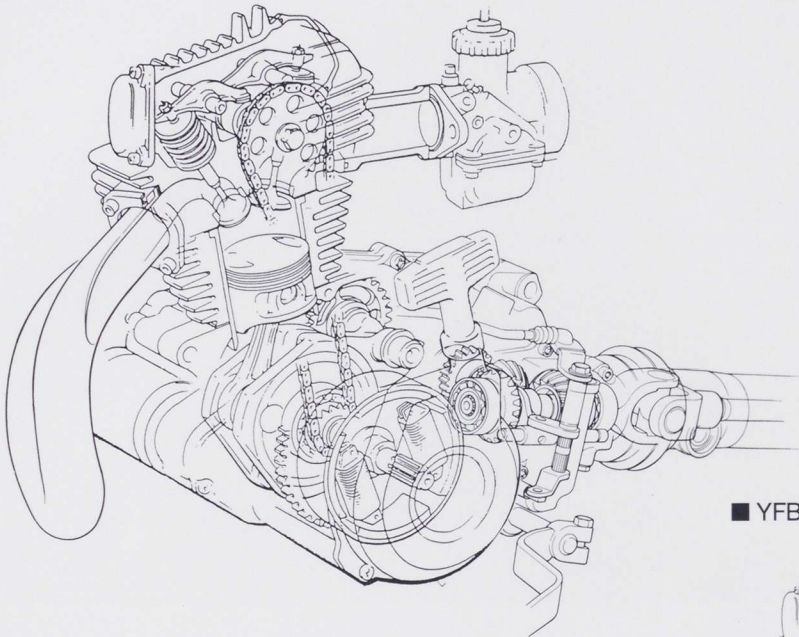

■ YFB250 (U.S. MODEL) ENGINE CUTAWAY

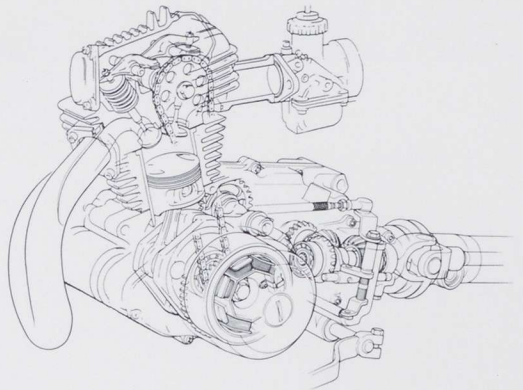

■ YFB250 (U.S. MODEL) AIR INTAKE

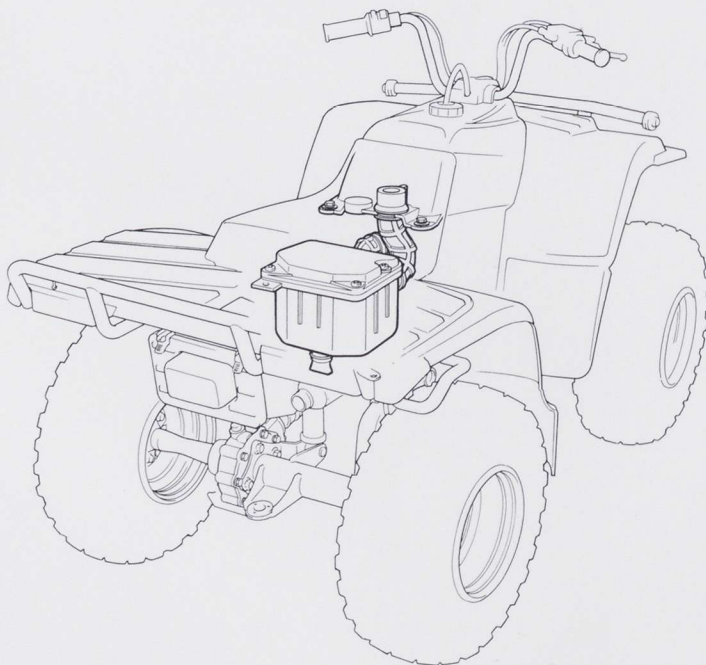

# Timberwolf

## ■ YFB250 (U.S. MODEL) FRONT SUSPENSION

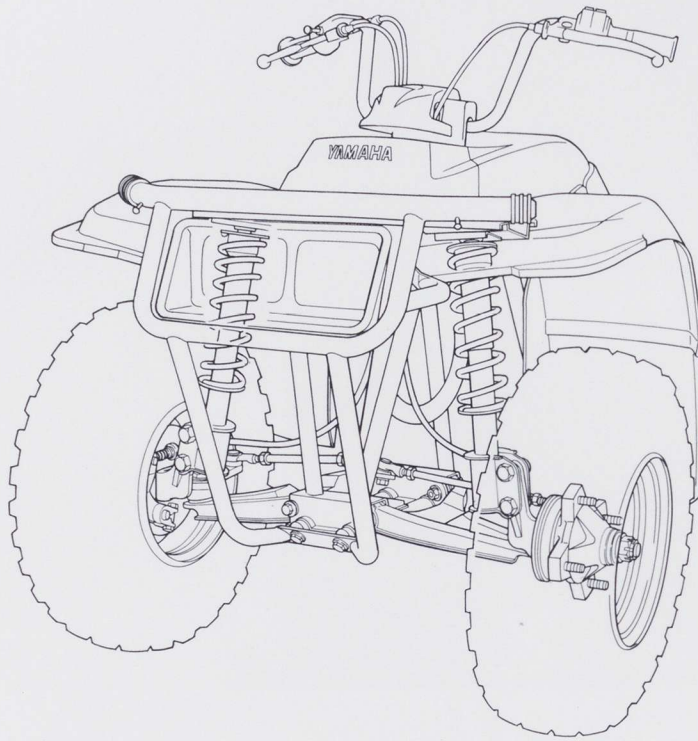

## ■ YFB250 (U.S. MODEL) REAR SUSPENSION

